

# Propeller Shaft

## DRIVE SHAFT SYSTEM

### 2. Propeller Shaft

#### A: REMOVAL

##### NOTE:

Before removing propeller shaft, wrap the metal parts attached to the rubber boot of center EDJ with a cloth or rubber material, as shown in the figure. The rubber boot may be damaged due to interference with adjacent metal parts while bending the EDJ during removal.

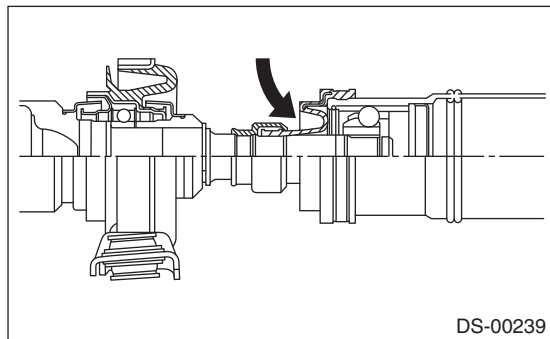

- 1) Shift the select lever or gear shift lever to neutral.
- 2) Release the parking brake.
- 3) Lift up the vehicle.
- 4) Remove the center exhaust pipe.
- 5) Remove the rear exhaust pipe and muffler.
- 6) Remove the heat shield cover.

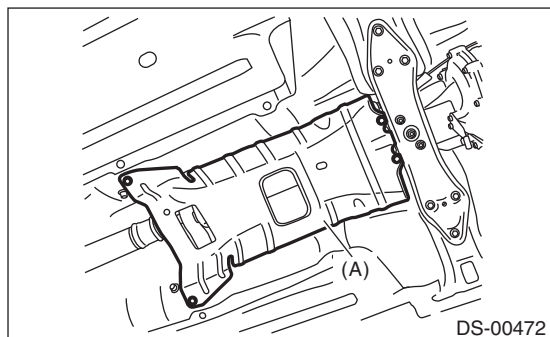

(A) Heat shield cover

- 7) Place alignment marks on the flange yoke and rear differential.
- 8) Remove four bolts holding the propeller shaft to the rear differential.

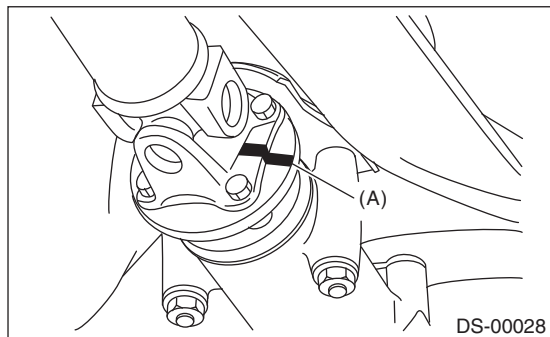

(A) Alignment mark

- 9) Remove the center bearing.

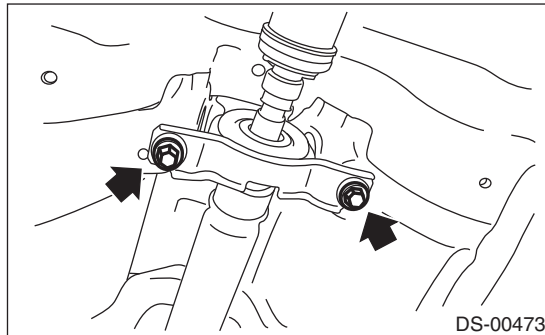

- 10) Remove the propeller shaft from transmission.

##### NOTE:

- Use a container to catch ATF or oil flowing from propeller shaft.
- To prevent ATF from leaking, install extension cap etc. to the transmission.

#### B: INSTALLATION

- 1) Insert the sleeve yoke into the transmission and attach center bearing to body.

##### Tightening torque:

**52 N·m (5.3 kgf-m, 38.4 ft-lb)**

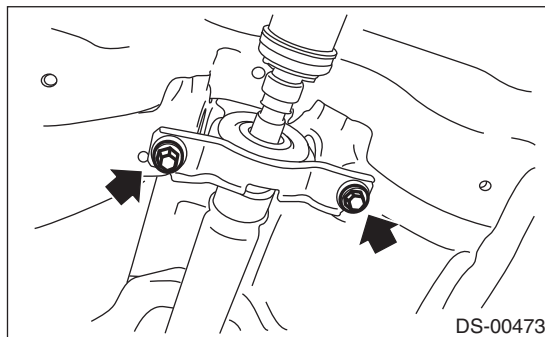

- 2) Align the alignment marks and connect the flange yoke and rear differential.

##### Tightening torque:

**31 N·m (3.2 kgf-m, 22.9 ft-lb)**

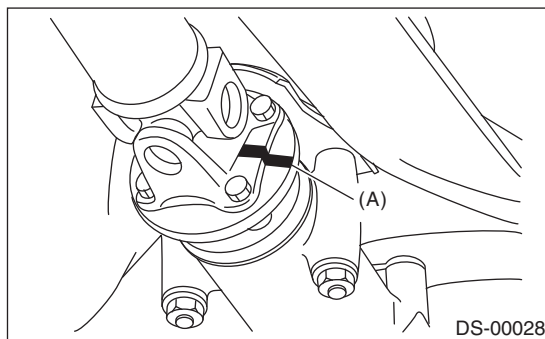

(A) Alignment mark

- 3) Install the heat shield cover.

##### Tightening torque:

**18 N·m (1.8 kgf-m, 13.3 ft-lb)**

- 4) Install the center exhaust pipe.
- 5) Install the rear exhaust pipe and muffler.
- 6) Lower the vehicle.

## C: INSPECTION

### NOTE:

Do not disassemble the propeller shaft. Check the following and replace if necessary.

- Tube surface for dents or cracks
- Splines for deformation or abnormal wear
- Unsmooth joint operation or abnormal noise
- Center bearing for free play, noise or non-smooth operation.
- Oil seals for abnormal wear or damage
- Damaged center bearing

Check the following points with propeller shaft installed in vehicle.

### 1. JOINTS AND CONNECTIONS

- 1) Remove the center exhaust pipe.
- 2) Remove the heat shield cover.
- 3) Check for any looseness of the yoke flange mounting bolts which connect to the rear differential and center bearing bracket mounting bolts.

### 2. SPLINES AND BEARING

- 1) Remove the center exhaust pipe.
- 2) Remove the rear exhaust pipe and muffler.
- 3) Remove the heat shield cover.
- 4) Turn the propeller shaft by hand to see if abnormal free play exists at splines. Also move yokes to see if abnormal free play exists at spiders and bearings.

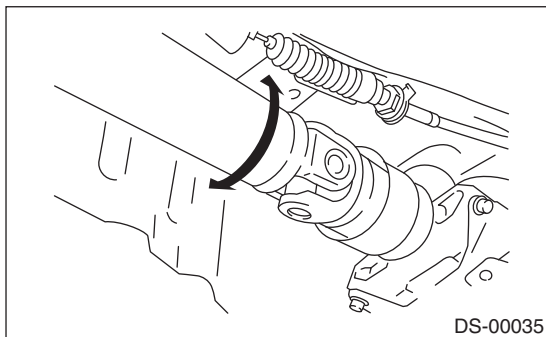

### 3. RUNOUT OF PROPELLER SHAFT

- 1) Remove the center exhaust pipe.
- 2) Remove the rear exhaust pipe and muffler.
- 3) Remove the heat shield cover.
- 4) Set the dial gauge with its indicator stem at the center of the propeller shaft tube.
- 5) Turn the propeller shaft slowly by hands to check for runout of the propeller shaft.

### Runout:

**Service limit 0.6 mm (0.024 in)**

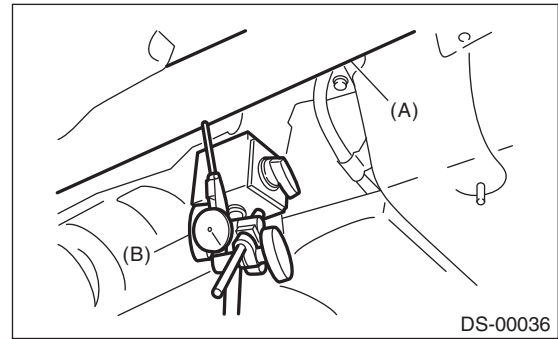

- (A) Propeller shaft  
(B) Dial gauge

### 4. CENTER BEARING FREE PLAY

- 1) Remove the front and center exhaust pipes.
- 2) Remove the rear exhaust pipe and muffler.
- 3) Remove the heat shield cover.
- 4) Move the propeller shaft near the center bearing up, down, left, right by hand, to check for any abnormal free play of the bearings.

